

W4-SERIES FERTIGATION



General Description:

The W-4 series consists of one to three metering pumps available in seven sizes, driven by our exclusive Green Scorpion™ control system. The system is designed to be used with all types of liquid fertilizers. The pump is motor driven and controlled using the latest VFD technology. The control system operates the pump and allows for simple rate programming, while keeping track of product usage and tank levels. The system runs proportional to flow and is ideal for Golf Course use. This unit incorporates our state-of-the-art GS7™ Control System for unprecedented ease-of-use as well as online remote control capabilities.

Features:

- Liquid end is compatible for use with all fertilizer materials.
- The unit is mounted on a rugged stainless steel frame.
- Pre wired and plumbed for easy installation.
- High efficiency VFD design.
- User friendly controls.
- Expandable (More Pumps, PC Control, etc.)
- Made in the USA.

WERECON Inc.

3320 N. 29th Ave. / Phoenix, AZ 85017 / 1-888-WERECON / www.werecon.com

W-4 Series Technical Information

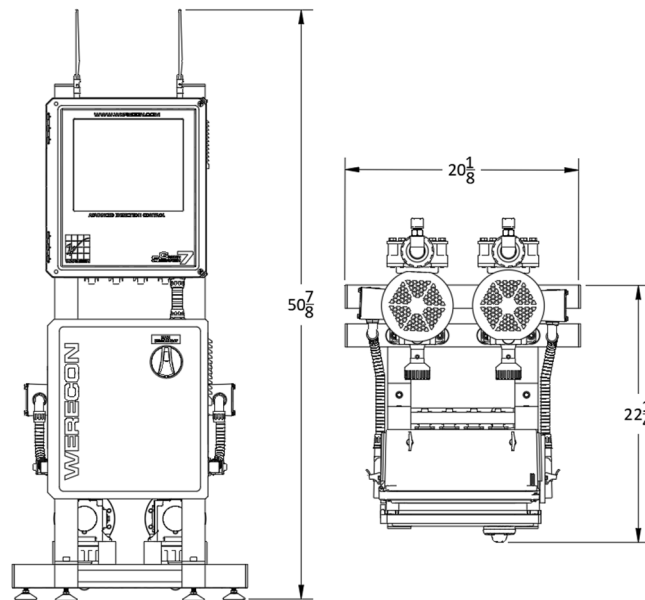

BASE CHASSIS DRAWING - ACTUAL LAYOUT MAY VARY.

Typical Specifications

Dimensions	21"W x 23"D x 51"H
Frame Construction	304 Stainless Steel
Diaphragm	PTFE
Liquid end	PVDF or 316 Stainless Steel
Seals	Viton A
Check valves	Ceramic/PVDF/316SS
Motor Type	230/480 3 phase provided by on board VFD.
Input Power	110-120VAC 1phase at 10-20 AMP
Pump capacity	15.9, or 31.8 GPH
Pressure max.	120-150 Depending on Size
Weight	approx. 135 lbs

Pre wired power cordset for standard 120VAC Outlet.

Distributed by:



www.centaur-asiapacific.com
info@centaur-asiapacific.com

*Hong Kong, Macau, Singapore, Malaysia, Indonesia, Vietnam, Thailand, China, Guam and other parts of Asia.

WERECON Inc.

3320 N. 29th Ave. / Phoenix, AZ 85017 / 1-888-WERECON / www.werecon.com